

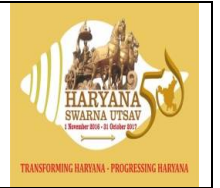

Deenbandhu Chhotu Ram Thermal Power Project, Yamuna Nagar
A Unit of Haryana Power Generation Corporation Ltd.
(Regd. Office-C-7, Urja Bhawan, Sector-6, Panchkula)
Corporate Identity Number: U45207HR1997SGC033517
(Phone No. 01732-204521, Fax. No. 01732-204521/204510)
Mobile No.: 9355061836, Email: xenproc1.dcrtp@hpgcl.org.in



DRAFT NOTICE INVITING TENDER (E-TENDER)

Tender Enquiry No.: DCRTPP/POM-13925

Date: 16.10.2024

Chief Engineer/DCRTPP, HPGCL, Yamuna Nagar invites sealed tenders in two parts from the eligible bidders for the under mentioned supply:-

NIT No.	Description	Tender Fee (Rs.) (Non – refundable)	EMD (Rs.)	e-service Fees (Rs.)	Last date of submission of EMD online	Last date of submission of Bids online
POM-13925	Supply of Seal Wear Ring	1,180/-	10,500/-	1,180/-	10.11.2024	12.11.2024 (13:00 Hours)

Information Regarding Online Payment of Tender Document , eService & EMD Fee.

The Bidders can download the tender documents from the Portal: <https://etenders.hry.nic.in>.

The Bidders shall have to pay for the Tender documents, EMD Fees & eService Fee online by using the service of secure electronic payment gateway. The secure electronic payments gateway is an online interface between contractors and online payment authorization networks. The Payment for Tender Document Fee and eService Fee can be made by eligible bidders/ contractors online directly through Debit Cards & Internet Banking Accounts and the Payment for EMD can be made online directly through RTGS / NEFT.

Exemption in tender document fee is applicable for the firms registered as MSME Haryana only. Firm registered outside Haryana as MSME shall have to pay tender document fee of Rs. 1180/- plus e-service Fee.



NOTE: If the tenders are cancelled or recalled on any grounds, the tender document fees & e-service fee will not be refunded to the bidder.

The Tenderers can submit their tender documents (Online) as per the dates mentioned in the key dates:-

Key Dates

Sr. No.	Activities	Date and time
1	Tender Publishing	16.10.2024 17.00 Hours
2.	Start of Bid submission	16.10.2024 13.00 Hours
3	Last submission of EMD	10.11.2024 00.00 Hours
4	Expiry of Bid submission	12.11.2024 13.00 Hours
5	Technical Opening (Part-I)	15.11.2024 15.00 Hours
6	Short listing of Technical bids & Opening of Financial Bid	Will be intimated to the firms later on their E-mail

Executive Engineer/Proc-I.
for Chief Engineer,
DCRTPP, HPGCL,
Yamuna Nagar

 <p>HPGCL AN ISO 9001, 14001 & OHSAS 18001 CERTIFIED COMPANY</p>	<p>Deenbandhu Chhotu Ram Thermal Power Project, Yamuna Nagar A Unit of Haryana Power Generation Corporation Ltd. (Regd. Office-C-7, Urja Bhawan, Sector-6, Panchkula) Corporate Identity Number: U45207HR1997SGC033517 (Phone No. 01732-204521, Fax. No. 01732-204521/204510) Email: xenproc1.dcrtp@hpgcl.org.in</p>	 <p>HARYANA SWARNA UTSAV TRANSFORMING HARYANA - PROGRESSING HARYANA</p>
--	--	--

NIT No. POM-13925

Instructions to bidder on Electronic Tendering System

1. Registration of bidders on e-Procurement Portal:-

All the bidders intending to participate in the tenders processed online are required to get registered on the centralized e - Procurement Portal i.e. <https://etenders.hry.nic.in>. Please visit the website for more details.

2. Obtaining a Digital Certificate:

2.1 The Bids submitted online should be encrypted and signed electronically with a Digital Certificate to establish the identity of the bidder who is bidding online. These Digital Certificates are issued by an Certifying Authority Approved, by the Controller of Certifying Authorities, Government of India.

2.2 A Digital Certificate is issued upon receipt of mandatory identity (i.e. Applicant’s PAN Card) and Address proofs and verification form duly attested by the Bank Manager / Post Master / Gazetted Officer. Only upon the receipt of the required documents, a digital certificate can be issued. For more details please visit the website – <https://etenders.hry.nic.in>.

2.3 The bidders may obtain Class-II or III digital signature certificate from any Certifying Authority or Sub-certifying Authority authorized by the Controller of Certifying Authorities or may obtain information and application format and documents required for the issue of digital certificate from:

Contact Us

For queries on Tenders Haryana Portal, kindly contact
 Note- Bidders are requested to kindly mention the URL of the Portal and Tender Id in the subject while emailing any issue along with the Contact details. For any issues/ clarifications relating to the tender(s) published kindly contact the respective Tender Inviting Authority.
Tel: 0120-4200462, 0120-4001002
Mobile: 8826246593
E-Mail: support-eproc[at]nic[dot]in

For any technical related queries please call at 24 x 7 Help Desk Number

0120-4001 002
0120-4200 462
0120-4001 005
0120-6277 787

International Bidders are requested to prefix 91 as country code

Email Support
 A) For any Issues or Clarifications relating to the published tenders, bidders are requested to contact the respective Tender Inviting Authority

Technical - support-eproc[at]nic(dot)in

2.4 Bid for a particular tender must be submitted online using the digital certificate (Encryption & Signing), which is used to encrypt the data and sign the hash during the stage of bid preparation & hash submission. In case, during the process of a particular tender, the user loses his digital certificate (due to virus attack, hardware problem, operating system or any other problem) he will not be able to submit the bid online. Hence, the users are advised **to keep a backup of the certificate** and also keep the copies at safe place under proper security (for its use in case of emergencies).

2.5 In case of online tendering, if the digital certificate issued to the authorized user of a firm is used for signing and submitting a bid, it will be considered equivalent to a no-objection certificate/power of attorney /lawful authorization to that User. The firm has to authorize a specific individual through an authorization certificate signed by all partners to use the digital certificate as per Indian Information Technology Act 2000. Unless the certificates are revoked, it will be assumed to represent adequate authority of the user to bid on behalf of the firm in the department tenders as per Information Technology Act 2000. The digital signature of this authorized user will be binding on the firm.

2.6 In case of any change in the authorization, it shall be the responsibility of management / partners of the firm to inform the certifying authority about the change and to

obtain the digital signatures of the new person / user on behalf of the firm / company. The procedure for application of a digital certificate however will remain the same for the new user.

2.7 The same procedure holds true for the authorized users in a private/Public limited company. In this case, the authorization certificate will have to be signed by the directors of the company.

3 Opening of an Electronic Payment Account:

Tender document can be downloaded online. Bidders are required to pay the tender documents fees online using the electronic payments gateway service. For online payments guidelines, please refer to the Home page of the e-tendering Portal <http://etenders.hry.nic.in>.

4 Pre-requisites for online bidding:

In order to bid online on the portal <http://etenders.hry.nic.in> , the user machine must be updated with the latest Java. The link for downloading latest java applet is available on the Home page of the e-tendering Portal.

5 Online Viewing of Detailed Notice Inviting Tenders:

The bidders can view the detailed N.I.T and the time schedule (Key Dates) for all the tenders floated through the single portal eProcurement system on the Home Page at <http://etenders.hry.nic.in>.

6 Download of Tender Documents:

The tender documents can be downloaded free of cost from the e-Procurement portal <http://etenders.hry.nic.in>.

7 Key Dates:

The bidders are strictly advised to follow dates and times as indicated in the online Notice Inviting Tenders. The date and time shall be binding on all bidders. All online activities are time tracked and the system enforces time locks that ensure that no activity or transaction can take place outside the start and end dates and the time of the stage as defined in the online Notice Inviting Tenders.

8 Bid Preparation (Technical & Financial) , Payment of Tender Document Fee, eService fee, EMD fees and Submission of online Bids:

8.1 The online payment for Tender document fee, eService Fee & EMD can be done using the secure electronic payment gateway. The Payment for Tender Document Fee and eService Fee can be made by eligible bidders/ contractors online directly through Debit Cards & Internet Banking Accounts and the Payment for EMD can be made online directly through RTGS / NEFT .

The secure electronic payments gateway is an online interface between contractors and Debit card / online payment authorization networks.

The Tender Document Cost including E-service cost shall be paid online through Debit card or net banking and EMD shall be paid through RTGS/NEFT. Confirmation of receipt of the above costs is must before final submission of the tender. RTGS/NEFT may take 48 hrs. for clearance, therefore, EMD should be paid well in time so that tender can be submitted within closing date of tender.

8.2 The bidders shall **upload** their technical offer containing documents , qualifying criteria, technical specification, schedule of deliveries, and all other terms and conditions except the rates (price bid).

The bidders shall **quote** the prices in price bid format.

8.3 Submission of bids will be completed by submission of the digitally signed & sealed bid as stated in the time schedule (Key Dates) of the Tender.

9 Tender Closing:

After the submission of bid by the bidders, the bidding round will be closed. Once the online tender is closed, no new Vendor can bid in the tender.

NOTE:-

(A) The bid will be accepted only online on the portal <https://etenders.hry.nic.in>. No Hard copy of any part will be accepted and will not be considered for processing at any stage. The Executive Engineer has the right to verify the authentication of the documents submitted by the bidder online

(B) If bidder fails to complete the Online Bid Submission stage on the stipulated date and time, his/hers bid will be considered as bid not submitted, and hence not appear during tender opening stage.

(C) From the starting date of Tender downloading to final date of submission of bid, the bidder can rework on his bid number of times he wants. If bidder submits the revised bid including price bid, original bid will automatically deleted and this revised bid will become original bid. No revised bid will be submitted after Part-I (Technical Bid) is opened.

(D) Complete bid will only be submitted after realization of tender document's fee and EMD.

(E) Bidders participating in online tenders shall check the validity of his/her Digital Signature Certificate before participating in the online Tenders at the portal <http://etenders.hry.nic.in>.

(F) For help manuals please refer to the 'Home Page' of the e-Procurement website at <https://etenders.hry.nic.in>, and click on the available link 'How to..?' to download the file. Bidders may also call at Toll free no. 0120-4001002 and 0120- 4200462.

for Executive Engineer/Proc-I.
Chief Engineer,
DCRTPP, HPGCL,
Yamuna Nagar



Deenbandhu Chhotu Ram Thermal Power Project, Yamuna Nagar
A Unit of Haryana Power Generation Corporation Ltd.
(Regd. Office-C-7, Urja Bhawan, Sector-6, Panchkula)
Corporate Identity Number: U45207HR1997SGC033517
(Phone No. 01732-204521, Fax. No. 01732-204521/204510)
Email: xenproc1.dcrtp@hpgcl.org.in

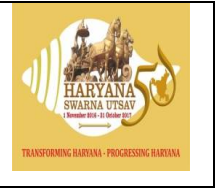

NIT No. POM-13925

INSTRUCTIONS TO THE BIDDERS

1. Pre Qualification Requirements (PQRs) / Eligibility Conditions for the tenderers:

The tender of only those bidders shall be considered who fulfill the following eligibility criteria and furnish duly signed/stamped documentary evidences along with the Part-I tender in support of the same:

- (i) The bidder should be original equipment manufacturer/supplier (OEM/OES) or registered vendor of HPGCL, as per vendor registration policy for the **supply of Seal Wear Ring.**

OR

The Bidder must have experience of having successfully executed Purchase Order(s) in HPGCL / NTPC / any SEBs / any PSUs /any Corporations / Central Govt. / State Govt. / Semi Govt. or in any Thermal/ Hydel Plant.

- (ii) **Experience of execution of Purchase order:**

Bidders must have successfully executed the purchase order(s) for the same or similar item(s) during last 7 years ending last day of the month previous to the month in which applications are invited having minimum order value as under:

Single order of the value not less than Rs. 4,18,000/- OR

Two orders of the value not less than Rs. 2,61,100/- each OR

Three orders of the value not less than Rs. 2,09,000/- each.

(The bidder has to Submit the PO copies as per above details. The bidders shall submit the copies of purchase orders executed & other documents duly signed/stamped on each page in respect of qualifying requirements).

- (iii) **Non-blacklisting Certificate:** Tenderer shall submit a certificate to the effect that the tenderer is not black listed from any Public Sector undertakings of Central Govt./State govt./SEBs/ Corporations/any other reputed thermal plant.
- (iv) The bidder has to submit the duly signed/stamped copy of complete set of Tender documents as a token of acceptance of all terms & conditions.
- (v) Bidder to certify that bidder is having own testing facilities or the same to be carried out at any Govt. Approved Test House.
- (vi) The bidder has to submit copy of GST Registration Certificate under GST Act.
- (vii) The Bidder has to submit the certified copy from Chartered Accountant for Average Annual Turnover certificate (MAAT) for last three consecutive FY (2021-22, 22-23, 23-24). And it should not be less than 21 Lakh.
- (viii) The following undertakings (on bidder's letterhead) have to be submitted along with technical bit (Part-I):-
- GST Registration is valid as on date
 - No default has ever been made by bidder in filling the various GST returns and deposit of GST dues with the department.
 - If the bidder is having multiple registrations under GST, bidder will submit undertakings for each and every GST number. Default under GST number even if the GST number pertains to some other state, will make the bidder ineligible to participate in tender.

The bidder should submit complete and correct documents in the first instance to avoid disqualification.

Depending upon the evaluation of Part-I tenders by the DCRTTP committee, Part-II tenders of successful bidders would be opened accordingly. Decision of the HPGCL regarding fulfillment of pre qualification requirement shall be final and binding upon the bidders.

Note: -

- The firm should fill statement to bidders as per annexure-2 of General Terms & Conditions and submit authentic supporting documents for proving its credential. Original document may be asked for verification at the time of finalizing the tender.**
- The special benefits / concessions to the Haryana based micro, small & medium industrial enterprises as extended by Haryana Govt. in O/o No.: 2/2/2016-4IBII(1) Dated: 20.10.2016 are applicable.**
- Bidder to submit Haryana Manufacturing MSME Certificate alongwith affidavit to claim benefits/concessions as per annexure-D-1. Benefits/concessions are only applicable for Haryana based Manufacturing MSME certificate.**
- Exemption in tender document fee is applicable for the firms registered as MSME Haryana only**
- Bidder has to submit NSIC Certificate to claim exemption in EMD.**

Criterion for Evaluation of Blacklisting:

The firms who have been blacklisted by HPGCL or any other Centre or State Power Utility/Board or Corporation/or any other Thermal/Hydro Elect. Project shall not be eligible to bid against the NIT of HPGCL, however:

- (i) In case the blacklisting of the firm is for a specific plant and not for the organization as a whole then such blacklisting will not tantamount to ineligibility of the bidder.
- (ii) Blacklisting of the firm by any Unit of HPGCL shall be considered as ineligibility of the firm at any other project of HPGCL.
- (iii) In case any firm was blacklisted for a limited period in past by any organization and presently such blacklisting has been removed by such organization then it will not tantamount to ineligibility of the bidder.
- (iv) Firm has to certify itself for its eligibility with supporting documents to participate in the NIT stating that it has not been blacklisted by any organization presently, however in case at a later stage if such certification is found wrong then it will lead to misrepresentation of facts and the firm shall be treated as blacklisted on this ground and action shall be taken as per regulation 36 and 37.

Decision of the HPGCL regarding fulfillment of pre qualification requirement shall be final and binding upon the bidders.

2. a) Conditions of the contract and other information can be had from the office of XEN/Proc-I (E-mail: xenproc1.dcrtp@hpgcl.org.in) on any working day prior to last date of Downloading of Tender Documents & Bid Preparation.
- b) Cost of Tender and EMD in any other form shall not be accepted.
- c) The firm shall also submit the Company profile & Details of manufacturing facility & equipments available with the firm alongwith their part-I bid. All the documents should be duly signed/stamped by the bidder.

The bidder should submit complete and correct documents in the first instance to avoid disqualification.

Depending upon the evaluation of Part-I tenders by the DCRTTP committee, Part-II tenders of successful bidders would be opened accordingly. Decision of the HPGCL regarding fulfillment of pre qualification requirement shall be final and binding upon the bidders.

Note:- The firm should fill statement to bidders as per annexure-2 of General Terms & Conditions and submit authentic supporting documents for proving its credential. Original document may be asked for verification at the time of finalizing the tender.

3. The Tender Document can also be seen on HPGCL website www.hpgcl.org.in.
4. Before submitting tenders the instructions may be read carefully regarding submission of tender. If any bidder finds discrepancies or omissions in the tender documents or is in doubt as to the true meaning of any part, he shall clarify same from tender issuing office in writing before the due date and time of submission of the bid.
5. The tenderer shall only be submitted on the centralized e - Procurement Portal i.e. <https://etenders.hry.nic.in>.
6. The tenderers will quote their rates strictly as per details of material specifications.
7. Tenders through Fax / E-mail / telegraphic tenders shall not be considered. Incomplete, obscure or irregular tender is liable for rejection. If the tenderer deliberately gives wrong information in his tender, HPGCL reserves the right to reject such tender at any stage.
8. The "Application for Bidding" along with the 'Terms and Conditions of the contract' and its Annexures should be submitted in duplicate duly filled up completely and stamped/signed on each page by the tenderer. Material offered should be strictly according to the specifications laid down in Annexure -I to the terms & conditions of the NIT. Unless a deviation from the specifications given in Annexure I is pointed out by the tenderer specifically, it will be presumed that Offer/Tender conforms to the specifications as laid down in Annexure-I.
9. All tenders received against open tender enquiry irrespective of whether they are from the approved contractors on the registered list or others, shall be considered, provided they are on the prescribed form and in accordance with the tender conditions and specifications.
10. Unless exempted specifically, tenders not accompanied with the prescribed EMD/Cost of Tender shall be rejected. EMD/Cost of Tender shall be in the prescribed mode of payment as asked in the NIT, otherwise, the tender shall be liable to be rejected.
11. Suo-moto revised price bid/supplementary Part-II will not be accepted after last date of submission of the tender.
12. The validity of the tender/ quotation should be at least for 120 days from the date of opening of price bid. If the firms are unable to keep their offer open for the specified period, they should specifically state the period for which their offer will remain valid but they must realize that such a provision may prevent their offer from being considered. However, the day up to which the offer remains valid is declared as Holiday for HPGCL offices, the offer shall be considered valid for acceptance till next working day.
13. The delivery period as stipulated in the delivery schedule (Annex-1 of general terms & conditions) is the essence of the contract. Delivery schedule should be specific and realistic and should not be too long or too short. Range of delivery schedule may be accepted only in case of delivery in lots, where it means delivery is to be started from lower range and will be finished up to higher range. Delivery period shall be reckoned from the 7th day of issue of P.O. / L.O.I whichever is earlier.
14. **Any statutory taxes/duties/other levies, if to be charged extra should be clearly indicated by tenderer in their offer separately, failing which it will be presumed that their quoted prices are inclusive of all such statutory taxes/ duties/other levies.**
15. Negotiation will be held as per negotiation policy of HPGCL and Amendment therfeof applicable from time to time.
16. Rates shall be quoted by the tenderer, item wise with price breakup on FOR destination basis. No deviation in terms shall be allowed. However, if not provided separately, then loading of Packing & Forwarding, Freight and Transit Insurance shall be done, for comparison purposes, as under:
 - (i) Packing & Forwarding: @ 0.5% of basic rate.

- (ii) Freight: @ 4% of basic rate.
- (iii) Transit Insurance: @0.25% of basic rate.

However item wise L1 will be considered for finalization of PO.

17. No deviation from the terms & conditions of tender shall be accepted. Once bidder submits the tender online, it is presumed that all the terms & conditions are accepted including payment terms.
18. Purchase preference of the tendered quantities may be allowed as per policy of the State Government to the Industrial Units located in Haryana on the lowest valid rates if tenderer so claim with requisite documentary evidence
19. The bidders / suppliers / contractors shall observe the highest standard of ethics during the submission of tender, procurement and execution of the contract. In case of evidence of cartel formation by the bidder(s), EMD is liable to be forfeited.
20. The bidder shall bear all costs associated with the preparation and submission of his bid, and the purchaser will in no case be responsible or liable for those costs, regardless of the conduct or outcome of the bidding process.
21. Opening of Tender:-
The tenders will be opened in the office of XEN/Proc.-I, DCRTTP, HPGCL, Yamuna Nagar in the presence of authorized representative of the tenderers, if they so desire, at the time and date set for opening of tenders or in case any extension was given thereto on the extended tender opening date and time. Tenderer's authorized representatives (up to two persons) may attend the opening.
 - a. The Price Bid (Part-II of the tender) shall be opened after Part-I of the tenders have been scrutinized and evaluated. The tenderers whose Part I have been approved, will be allowed to participate in opening of Price Bid (Part-II). The due date and time for opening of Price Bid (Part-II) shall be informed later on. The Tenderer shall deposit requisite Earnest Money along with the tender to ensure that the tenderer takes up the contract in right earnest. An EMD amounting to **Rs. 10,500/-** is applicable.
 - i) The EMD of the successful tenderer will be adjusted against security deposit in the event of placement of order. EMD of unsuccessful tenderer will be refunded on finalization of contract.
 - ii) No interest shall be payable on Earnest Money Deposit.
 - iii) HPGCL reserves the right to forfeit Earnest Money Deposit or part thereof in circumstances which may indicate that the contractor is not earnest in executing the contract. EMD shall also be forfeited in case the bidder does not come forward for execution of the contract agreements and submission of balance security deposit.
 - iv) If the tenderer withdraws his tender at any stage during the currency of his validity period, the earnest money shall be forfeited in full in such cases.
22. Purchaser reserves the right to amend/ cancel the NIT or to change qualifying requirement or to reject any or all the tenders so received without assigning any reason.
23. It should be preferred that OEM/OES should quote the rates directly without taking dealer into loop.
24. If the price are quoted by the dealers, a certificate should be obtain from the OEM/OES by the dealer that the quoted rates by the said dealer are well in knowledge of OEM/OES.
25. If the dealer is called in SPC for negotiations/discussions of the rate, the representative of OEM/OES should also accompany with the dealer in the SPC.
26. **All the fields of BOQ shall be filled by the bidder**

Executive Engineer/Proc-I.
for Chief Engineer,
DCRTTP, HPGCL,
Yamuna Nagar

SCHEDULE 'C-1'
(Referred to in regulation 7)

GENERAL TERMS AND CONDITIONS OF CONTRACT (Supply order)

1) Definitions:-

In the contract (as defined below) unless the context requires otherwise the words and expressions defined below shall have the meaning hereinafter assigned to them.

- a) The 'Purchaser' shall mean the HPGCL and shall include its successors in office and assigns.
- b) The 'Supplier /Manufacturer' shall mean M/s._____ and shall include the Supplier's legal representatives, successors, and assigns.
- c) 'Material' shall mean and include the material to be supplied by the Supplier under the contract as per contract.
- d) 'Specifications' shall mean and include the specifications as detailed in the Annexure attached herewith and drawings attached thereto as well as samples and patterns, (if any).
- e) 'Drawing' shall mean the drawing /drawings annexed to the specification (if any) or as approved by the purchaser.
- f) The 'Site' shall mean and include lands & buildings over / under upon where the materials are to be installed and used in accordance with terms & conditions.
- g) 'Place of delivery' shall mean the place of delivery at which the Supplier is responsible to deliver the materials at the specified contract price.
- h) The terms 'F.A.S', 'F.O.R', 'F.O.B.', 'C.I.F.' and other shipping dispatch terms as used herein shall have meaning in accordance with their usage in India.
- i) 'Work' shall mean and include supply of all materials, plants and equipments and rendering of other services by the supplier under this contract.
- j) 'Consignee' shall mean the officer to whom the material is required to be dispatched or the person specified in the purchase order.
- k) 'Contract' shall mean the Notice Inviting the Tender, Tender Form, and conditions of contract with their annexure and Purchase Order / Acceptance of offer / tender/LOI/LOA.
- l) 'Purchasing Authority' shall mean the officer signing the acceptance of tender and shall include any officer who has authority to execute the relevant contract on behalf of the Purchaser.
- m) 'Purchase Order' shall mean an order of supply of material including the acceptance of the tender.
- n) 'Annexure' shall mean the Annexure to the terms & conditions.
- o) 'Test' shall mean such test as is prescribed by the ISI or by the HPGCL and / or considered necessary by the authorized agent of the Purchaser whether conducted / performed or made by him or any other agency acting under his direction.
- p) 'Delivery' shall be deemed to take place on delivery of material in accordance with terms of the Contract after test and inspection by the Purchaser or his authorized agent, to the consignee. If the rates are ex-works, date of dispatch/Goods Receipt (GR) and in case the rates are FOR destination, date of receipt of material in store in good conditions shall be treated as date of delivery.
- q) 'Inspecting Agency' means the agencies nominated and authorized by the competent authority for inspecting the material at the works of the supplier or at the designated place of inspection prescribed by the purchasing authority.
- r) 'Inspecting Officer' means, officer of the Corporation appointed by the Chief Engineer or the purchasing authority for inspection.
- s) 'Contract Value' shall mean the bare value of the goods 'ex-works price' without taking into account taxes, duties or any other incidental charges where the price is ex-works, but where the prices given in the PO are on FOR destination basis inclusive or exclusive of GST etc., the 'Contract value' would mean FOR destination prices, given in the PO inclusive of GST, other statutory levies etc. as the case may be.
- t) 'Total Contract Value' shall mean contract value plus statutory dues like GST etc. and any other amount payable under contract.

2) PARTIES:

The parties to the Contract are the Supplier and the Purchaser, Legal address of the Parties to the Contract is as under:

Supplier: M/s. On which P.O. is placed.

Purchaser: _____ Haryana Power Generation Corporation Ltd.

For all purposes of the contract, including the arbitration there under, the address of the Supplier mentioned above, shall be the address to which all communications addressed to the supplier shall be sent, unless the Supplier has specifically intimated a change thereof.

3) AUTHORITY OF THE PERSON SIGNING THE CONTRACT ON BEHALF OF THE SUPPLIER:-

It is presumed that the person who has signed these Tender-papers (including the terms and conditions) has got authority to sign on behalf of the supplier. If it is discovered at any time that the person so signing had no authority to do so, the purchaser without prejudice to any other right or remedy available to him, may cancel the contract and make a purchase of the material at the risk and cost of such person and hold such person liable to the purchaser for all costs and damages arising from the cancellation of the contract including any loss which the purchaser may sustain on account of such purchase.

4) PRICES:

- (i) Item wise prices with price breakup (i.e. cost price, freight, taxes and duties separately) shall be quoted by the bidders on FOR destination basis and shall remain FIRM during the currency of contract unless otherwise agree. No deviation in terms is allowed. However, if not provided separately, then loading of Packing & Forwarding, Freight and Transit Insurance shall be done, for comparison purposes, as under:
- (i) Packing & Forwarding: @ 0.5% of basic rate.
 - (ii) Freight: @ 4% of basic rate.
 - (iii) Transit Insurance: @0.25% of basic rate.

- (ii) GST, if charged extra, separately shall be paid as per actual within delivery period on production of following certificates:

Goods & Service Tax Certificate:- a) Certified that transactions on which tax has been claimed will be included in the return to be submitted to the sale tax authorities for assessment of GST and the amount claimed from the HPGCL shall be paid to the GST authorities.

b) Certified that the goods on which sales tax has been charged have not been exempted from sales tax under Haryana/ Central Sales Tax Act and Rules made there under. The charge on the account of the GST on these goods are correct under the provisions of the relevant act and rules made there under.

c) Certified that we shall indemnify to HPGCL in case it is found at a later stage that the incorrect payment has been recovered on account of GST by us.

d) Certified that we are registered as dealer/ manufacturer on GST and GST no. is _____. Our GST No. is _____.

Note: Any increase in taxes & duties after the delivery period shall be on the supplier's account and shall not be borne by HPGCL (The above note shall not be applicable in case supplier is a Govt./Semi-Govt./PSU).

(iii) ESCALATION/PRICE VARIATION CLAUSE.

No escalation shall be permitted in respect of any increase not arising out of the operation of any law and statutory or mandatory order of the Govt. of India or the concerned State Govt. In case the period of the purchase order for completion of supplies is more than one year and tenderer wishes to include an escalation clause in his quotation then bidder should provide full details of the escalation formula and bring out precisely the actual increase in the price of the finished item for every rupee worth of increase in each item of raw material/component of wages, to which the escalation applies. The tenderer shall furnish such documentary evidence, as may be required by the HPGCL, in support of the increase in respect of each item of raw material/component of wages etc. for which the escalation is claimed. No escalation/price variation shall be considered beyond the scheduled delivery period. However, for valuation of L1 bidder the total contract value for the contract period shall be considered.

(iv) Foreign Exchange variation:

In case of the contract for procurement is in foreign currency then the applicability of the foreign exchange variation should be clearly defined. The period of the applicability of the exchange variation should be restricted according to the delivery schedule. Ordinarily the exchange variation should not be permitted in the extended period of the delivery.

5) EARNEST MONEY AND SECURITY DEPOSIT:-

Every tenderer, while submitting his tender, shall deposit the earnest money specified in the NIT (**Rs. 10,500/-**) online by using service of secure electronic payment gateway directly through RTGS/NEFT. After the EMD payment confirmation, the bid can only be submitted. The secure electronic payment gateway is an online interface between contractors and online payment authorization networks.

The earnest money furnished by the successful tenderers on whom the purchase order is placed shall be converted into security deposit as a guarantee for faithful and satisfactory execution of the purchase order up to warranty period.

The EMD of the unqualified bidders will be returned by the purchaser without any interest, as promptly as possible, within 30 days after declaration of qualification result and that of unsuccessful bidders within 15 days of the execution of the contract with the selected bidder.

Provided further that the provision of this regulation may not apply to a Public Sector undertaking of the State Government, firms borne on D.G.S & D / DS&D Haryana rate contract, firm registered with Director of Industries, Haryana or with National small industries corporation, Govt. of India or the firms having permanent EMD of Rs.10.00 Lac at the respective project / office.

For Benefits / Concessions to the Haryana based Micro, Small and Medium Industrial Enterprises in the State Public Procurement as under (G.O. No.-02.02.2016-41B11 (1) dated 20.10.2016 please refer annexure-B, B-I & B-II.

The earnest money /security deposit shall be forfeited in part or in full under the following circumstances:-

- i) If the tenderer withdraws his tender at any stage during the currency of his validity period.
- ii). If the P.O. has been issued but the supplier refuses to comply with it.
- iii) Where the purchase order has been complied with but the supplier stops making the supplies after partially fulfilling the purchase order.
- iv) In the event of breach of a contract in any manner.
- v) In the case of evidence of cartel formation by the bidder(s).

In case where the Performance Bank Guarantee (PBG) has been agreed by the supplier, the security deposit shall be released on the completion of the supplies. In other cases the same shall

be released only after warrantee period on the certificate of the purchaser for satisfactory completion of the warrantee period.

No interest shall be paid on EMD for the period it remains deposited with HPGCL.

6) PAYMENT TERMS:-

Subject to any deductions which the purchaser may be authorized to make under this contract, the payment for the material shall be made as under:-

One hundred percent payment shall be made after 21 working days of receipt of material at site in good condition and after submission of 10 % PBG.

or

90% payment against documents through bank after 21 working days of receipt of information from the bank & after submission of 10 % PBG and balance 10% after receipt of material in good condition.

Note: Receipt of material at site shall mean receipt of material in accordance with terms of the Contract after test and inspection by the Purchaser or his authorized agent, along with the requisite documents specified in clause no. 10.

7) MODE OF PAYMENT:-

Payment shall be released by the Sr. Accounts Officer, DCRTTP, Yamuna Nagar by account payee cheque payable at Yamuna Nagar through RTGS/NEFT. For payment through RTGS/NEFT, the supplier will provide complete bank details viz. Name of Bank/Branch, Account Number, Type of Account, IFSC Code etc. to Sr. Accounts Officer, DCRTTP, Yamuna Nagar.

The firm will provide their GST registration No., HSN Code, PAN Number, place of business with address and a unique invoice number suffix with DCRTTP. So that the invoice could be distinguish with other place of business of HPGCL i.e. PTPS, FTGPP, FTSP, Corporate Office.

8) DELIVERY PERIOD AND DAMAGES FOR DELAY:-

The date of delivery of material as specified in the purchase order shall be the essence of the contract between the supplier and the Corporation, and the delivery of each consignment must be made as per delivery schedule.

No supplies/ consignments received after the date on which they were actually due according to the terms of the purchase order, shall be accepted by the consignee, except with the written approval of the purchasing authority. Even in case of acceptance of delayed supply the supplier shall be liable to pay @ 0.5% per week or part thereof of the delay of the value of the goods so delayed where the part supply is acceptable and of the PO value where part supply is not acceptable, subject to a maximum of 5% of the total value of the delayed / undelivered supplies.

The delivery period shall be reckoned from the 7th day of issue of P.O./ L.O.I. or agreed otherwise whichever is earlier.

Property in the material shall not pass to the purchaser unless and until the material has been delivered to the consignee in accordance with the terms and conditions of P.O..

9) TESTS AND INSPECTIONS:-

The tests and inspections shall normally be arranged at the supplier's premises before the material is dispatched to the Corporation, and copy of the inspection/ test report in such case shall be attached by the supplier in original along with Railway Receipt/ GR and other requisite document as per P.O. For this purpose, the supplier shall give at least 15 days notice to the purchasing authority to arrange for the inspection of goods offered for dispatch, on different occasions, before dispatch if inspection is not waived off. In addition to this, the supplier has to submit copy of test certificates along with inspection call. Without test certificates, pre-dispatch inspection call will not be accepted and delay on this account will be on the part of the supplier.

HPGCL has the right to get the pre-dispatch inspection done from third party along with HPGCL representative.

In case, the supplier is not having its own testing facility and any agency has not been specifically mentioned in the PO, then the supplier will submit the test certificates issued from any Govt. approved laboratory.

Supplier shall ensure that all the facilities necessary for carrying out the inspection/prescribed tests are made available to the inspection officer at the point of inspection to be carried out.

In case of non conduct of testing due to non availability of material, the charges of the inspecting officers shall be borne by the supplier.

The inspection call received after expiry of delivery period may or may not be entertained.

Supplier shall dispatch the material with copy of inspection report and manufacturer test certificate, immediately after inspection but not later than 7 (seven) days failing which the delay shall be on the part of supplier for the purpose of L.D. In case of waiver of inspection, supplier shall dispatch the material within 7 days of receipt of waiver letter or 10 days of dispatch of waiver letter whichever is earlier.

10) DOCUMENTATION:-

The supplier shall submit a set of documents as detailed below well in time to the following offices for processing his bill for pass and payment.

- A) Concerned Executive Engineer (Purchaser copy)-
- | | |
|-----------------------------------|---|
| a) Acceptance of PO | b) Readiness of material/ inspection call |
| c) Copy of invoice | d) Copy of RR/GR |
| e) Advance intimation of dispatch | f) Test Certificates |
- B) Concerned Sr. A.O. (Accounts copy)
- | | |
|---------------------------------------|-----------------------------------|
| a) Copy of invoice in triplicate | b) GST Certificate |
| c) Proof of Insurance charges | d) Guaranty/ Warranty Certificate |
| e) Interchangeability Certificate | f) Copy of inspection report |
| g) D.D on account of security deposit | h) Performance Bank Guaranty. |
| i) Copy of R.R./G.R. | |
- C) Concerned Executive Engineer/ Stores (Consignee copy)
- | | |
|-------------------------|------------------------------|
| a) Copy of Invoice. | b) Copy of Inspection Report |
| c) Dispatch particulars | d) Copy of RR/GR. |
- D) Appropriate branch of State Bank of Patiala, if document are to be negotiated through Bank
- | | |
|--------------------|---------------------|
| a) Copy of invoice | b) Original RR/ GR. |
|--------------------|---------------------|

Note:-

If the documents shown above are not sent to the appropriate office within due period then bank document will not be retired and the responsibility for demurrage/ wharfage or auction of material will be on the supplier's account.

No interest, what so ever on any account shall be paid by HPGCL.

Bank Charges if any shall be borne by the supplier.

11) PACKING:-

The supplier shall provide for secure protection & packing of the equipment in accordance with the best established Practices so as to protect the equipment from damages. Any breakage, damage and/or pilferage including when in transit arising from faulty packing shall be the responsibility of the supplier.

All packages shall be visibly marked mentioning purchase order number & name of buyer in bold letters & must contain copies of challans/packing slips inside.

12) MODE OF TRANSPORT:-

The normal mode of transport for dispatch of material from supplier's end shall be by train / approved road transporter of HPGCL.

13) TRANSIT INSURANCE:

- (A) The material shall be insured against all risks and loss for its full delivered value up to the destination station. The insurance charges from dispatching station up to the destination station will be borne as per provision in the PO. The Supplier shall produce insurance cover and also a stamped acknowledgement receipt of the insurance company for the premium paid by them in support of their claim, if any. The consignee shall report losses/damage to the Supplier at the earliest possible of the receipt of the consignment at the site.

It will, however, be the responsibility of the Supplier to prefer timely claim on the insurance underwriters. The Supplier will make good the losses / shortages, replace / repair the damage to the consignee irrespective of the claim lodged / to be lodged with the insurance underwriters or other appropriate authorities.

The Supplier shall supply or replace such material or parts as are lost in transit within reasonable time based on the delivery period free of charges.

The Supplier shall be responsible for all loss, destruction, damage, deterioration of the material from any causes whatsoever in the course of transit from the Supplier to the consignee. If insurance is in the scope of consignee, the firm will intimated to consignee advance about dispatch of material otherwise all the losses, if any will be in the account of supplier.

- (B) In case of supply of material against documents through bank, no material shall be accepted without proper transit insurance.

14) PERFORMANCE BANK GUARANTEE:-

Supplier shall submit bank guarantee of the Nationalized Bank equivalent to 10% of the order value in the prescribed Performa valid up to three month after completion of warrantee period unless otherwise agreed.

15) WARRANTEE:

The supplier shall be made responsible to replace free of cost, with no transportation or insurance cost to the Corporation, up to the destination the whole or any part of the material, which in normal and proper use proves defective in quality or workmanship, subject to the condition that the defect is noticed within 12 months from the date of use of material at site or 18 months from the date of receipt, whichever period may expire earlier. The consignee or any other officer of the corporation actually using the material will give prompt notice of each such defect to the supplier as well as the Purchasing Authority and the Sr. A.O. The replacement shall be effected by the supplier within reasonable time, but not, in any case, exceeding 45 days. The supplier shall, also, arrange to remove the defective supply within a reasonable period, but not exceeding 45 days from the date of issue of the notice in respect thereof, failing which, the corporation shall reserve the right to dispose off the defective material in any

manner considered fit by it at the sole risk and cost of the supplier. Any sale proceeds of the defective material after meeting the expenses incurred on its custody, disposal, handling etc. shall, however, be credited to the supplier's account and set off against any outstanding dues of the corporation against the supplier.

The supplier shall furnish warrantee certificate stating that, "we will be responsible to replace within 45 days of the date of issue of notice, free of cost, with no transportation or insurance-cost to the Corporation, up to the destination the whole or any part of the material supplied by us against P.O. No.- _____ dated _____, within a period of _____ which in normal and proper use proves defective in quality or workmanship, within 12 months from the date the material is received by the consignee or 18 months from the date of dispatch whichever is earlier".

The provisions shall, mutatis mutandis apply to the replaced material. In case the material is again found to be defective within a period of 12 months of its replacement, it shall also have to be replaced similarly (Guarantee/warrantee clause shall be applicable to the replaced material also).

16) FORCE MAJEURE:-

The delay in the delivery of the supply may be treated as force majeure to the supplier only if:-

- i) The delay in manufacture or delivery of the material /equipment on order result from any causes arising out of compliance with regulations, orders or instructions of the Central or State Governments, acts of God, acts of Civil & Military authority, fires, floods, strikes, lock-outs, freight embargoes, war-risk riots and civil commotion and
- ii) The supplier's request for extension of the delivery period along with all necessary evidence, before the expiry of the schedule date (s) of delivery.

Non -availability of raw material or any other similar cause shall not be considered as a force majeure circumstance.

17) DEMURRAGES:-

The Supplier shall be responsible for all demurrage charges due to late receipt of G.R. and non-receipt of prior intimation of dispatch of material to the consignee. G.R. through bank other than specified one will not be accepted. If any consignment and or its relevant shipping document are dispatched to an incorrect address / destination or parts of the case, the additional expenses involved & delay in delivery shall be to the Supplier's account.

18) ARBITRATION: -

All matters, questions, disputes, differences and / or claims arising out of and / or concerning, and /or in connection with, and /or in consequence of, and /or relating to the contract whether or not obligations of either of both the Supplier and the Corporation under that contract be subsisting at the time of such dispute and whether or not the contract has been terminated or purported to be terminated or completed, shall be referred to the sole arbitration of MD, HPGCL or an officer appointed by the MD, HPGCL as his nominee. The award of the Arbitrator shall be final and binding on both the parties to the contract.

The objection that the Arbitrator has to deal with the matters, to which the contract relates, in the course of his duties or he has expressed his views on any or all of the matters in dispute or difference, shall not be considered as valid objection.

The arbitrator may, from time to time, with the consent of the parties to the contract enlarge the time for making the award. The venue of the arbitration shall be the place from which the acceptance of offer is issued or such other place as the Arbitrator, in his discretion, may determine.

All arbitration proceedings under this regulation shall be governed by the provisions of the Arbitration and Conciliation Act, 1996 and the Rule there under, with any statutory modification thereof for the time being in force.

19) LAWS GOVERNING CONTRACTS:-

All contracts shall be governed by the laws of India for the time being in force.

Irrespective of the place of delivery, place of performance or place of payment under a contract, the contract shall be deemed to have been made at the place from which the acceptance of tender has been issued.

Jurisdiction of Courts- The courts of the place from where the acceptance of tender has been issued shall alone have exclusive jurisdiction to decide any dispute arising out of or in respect of the contract.

20) RISK PURCHASE:-

In the case of delay or non-supply of any or all the material on the dates they are due, the HPGCL will have a right to refuse to accept such delayed supplies and to make the purchase of the material so delayed or not supplied from any alternative source or through departmental manufacture, at the sole risk and cost of the supplier. Any extra expenditure incurred on such purchase or departmental manufacture shall be recoverable in full from the supplier in addition to the Corporation's right or claim for applicable liquidated damages or penalty.

21) INTERCHANGEABILITY:-

Supplier shall furnish interchangeability certificate, wherever applicable, that all the spares are identical in construction, interchangeable and suitable to the equipment installed at site.

22) SET OFF:-

Any sum of money due and payable to the supplier under the contract (including security-deposit returnable to the supplier) may be appropriated by the HPGCL and set-off against any claim of the Corporation for the payment of a sum of money arising out of under that or any other contract entered into by the supplier with the HPGCL.

23) PRESERVATION PROCEDURE:-

Supplier shall submit the preservation procedure in detail provided by OEM for the storage or handling of material in store.

24) E-WAY BILL & INVOICE:-

The supplier shall submit copy of E-Way bill with copy of invoice.

25) PATENT RIGHT:-

The supplier shall indemnify the Purchaser against all third-party claims of infringement of patent, trademark or industrial design rights arising from use of the Goods or any part thereof in India.

26) SUBLETTING AND ASSIGNMENT:-

The Supplier shall not, sublet, transfer or assign the contract or any part thereof or interest therein or advantage thereof in any part thereof in any manner whatsoever without prior consent of the purchaser.

Note:-1. Unless agreed otherwise the above terms and conditions of the contract will form the part of the purchase order after finalizing the procurement proposal. The word tenderer where ever used above shall be read as supplier. Above T&C are equally applicable in case of limited / proprietary enquiry as well. The non applicability / modification in the aforesaid clauses if agreed shall be mentioned / attached in / with the purchase order specifically.

2. Purchasing authority shall put dated initials on each pages of the purchase order including the above terms and conditions printed on both side of the paper.
 3. Any other term not defined in instructions to the bidder or above terms and conditions should be interpreted as defined in HPGCL Purchase Regulation “2015”.
 4. The term “Bid” and “tender” and their derivatives (“Bidder / Tenderer” “Bidding / Tendering”) are synonymous. Singular also means plural.
- 27) The terms and conditions not specified in the tender, shall be governed by “ HPGCL Work & Purchase Regulation 2015” which are available on the HPGCL website i.e. www.Hpgcl.org.in and amendment thereof.

for Executive Engineer/Proc-I.
Chief Engineer,
DCRTPP, HPGCL,
Yamuna Nagar

SPECIFICATIONS / SCHEDULE OF DEIVERY OF MATERIAL

Sr. No.	Description of Material	Qty	Unit	Basic Unit Rate	Unit P&F in % age	Unit GST in % age	Unit Freight in % age incl. GST	Unit Transit Insurance in % age	Unit Rate with taxes	Total Amount with Taxes	Total Amount in words	Consignee
1.	Seal Wear Ring, MOC-EN-31, Hardness-55 RC (minimum), Dimensions & specifications (As per attached Drawing)	21	Nos.	To be filled by firm	To be filled by firm	To be filled by firm	To be filled by firm	To be filled by firm	To be filled by firm	CALCULATED BY SYSTEM		XEN/Stores at DCRTTP, Yamuna Nagar;
2.	Trump Iron Spout MOC-MS Dimensions & specifications (As per drawing attached)	11										

Note:-

1. Tenderer are requested to confirm in their Part-I tender that material will be supplied strictly as per specifications given in the NIT.
2. Tenderer are requested to comment upon and accept all the terms and conditions of NIT. In case of non-comment of any terms and conditions, it will be assumed that these terms and conditions are acceptable to the tenderer.
3. The bidder shall quote minimum delivery period from the date of indent.

Following Details must be provided by the bidders in the Part-I offer, otherwise the tender is likely to be rejected.

i. P&F (inclusive)	ii. Damage for Delay (applicable)
iii. GST (specify %age against each item)	iv. G/W certificate (applicable)
v. Pre-dispatched Inspection (applicable)	vi. Proof of Transit Insurance (applicable)
vii. Interchangeability Certificate (applicable)	viii. Security Deposit(applicable)
ix. Test Certificate(applicable)	x. Freight (inclusive)
xi. Delivery period (03 months)	xii. Non-Blacklisting Certificate (attach copy)
xiii. Payment Terms(as per NIT)	xiv. Annual turnover certificate of last 3 yrs
xv. Relevant documents in support of EMD exemption if any.	xvi. Tender documents dully stamped and signed
xvii. Confirmation that material will be supplied strictly as per specifications given in the NIT.	
xviii. Confirm to agree and submit standard terms/conditions of Anexure-1, 2, 3 to Schedule C, Annexure4.	

for XEN/ Procurement-I,
Chief Engineer/DCRTTP,
HPGCL, Yamuna Nagar

STATEMENTS OF BIDDERS

1. Name of Bidder _____
2. Address of Head Office _____
3. Correspondence Address _____
4. E-mail ID _____
5. Mobile No. _____
6. Legal status _____
7. PAN & TIN Number of the Bidder (attached self attested photocopies)
PAN _____ TIN _____
GST No. _____.
8. Bank Details (attached signed cancelled cheque)
 - i) Bank Name & Address
 - ii) Bank Account Number
 - iii) Bank Branch Code
 - iv) IFSC Code of Branch
 - v) Nature of account (current/saving/OD/CC)
9. Main lines of Business
 - i. _____ since _____
 - ii. _____ since _____
 - iii. _____ since _____
10. Annual Turnover of past three year (attached Certified copy from CA)
 - i. 2021-22 _____
 - ii. 2022-23 _____
 - iii. 2023-24 _____
11. Past Experience of purchase order executed in last 7 years as per PQR.

Name of Organization	Date	Detail of Material	Order Value of PO

12. Any other

Signature & Stamp of Bidder

ANNEXURE-'3' to Schedule-'C'

Benefits / Concessions to the Haryana based Micro, Small and Medium Industrial Enterprises in the State Public Procurement as under (G.O. No.-02.02.2016-41B11 (1) dated 20.10.2016) & G.O. No:-2/2/2016-41B11 (2) DATED 20.10.2016 regarding performance security deposit) :-

A. Concessions / Benefits to Micro and Small Enterprises (MSEs):-

Sr. No.	Area as part of qualifying requirements	Concessions / benefits allowed to MSEs	Eligibility
1	Tender Fee	Exemption on the payment of tender fee subjected to fulfillment of conditions as per eligibility	<p>Manufacturing Micro & Small Enterprises(MSEs) (Including Khadi & village Industries/Units) who have filed Entrepreneur Memorandum in Haryana in respect of the quoted items, participate directly in tender and not through any intermediaries (their dealers/agent/distributors), will not subcontract to any other firm and to carry the entire manufacturing at their enterprise.</p> <p>Concerned MSE will be required to submit the copy of Entrepreneurs Memorandum in respect of its category of Micro/small issued to the firm by the Industries Department Haryana as part of Technical Bid.</p> <p>Manufacturing Micro & Small Enterprises(MSEs) (Including Khadi & village Industries/Units) who have filed Entrepreneur Memorandum in Haryana and further:-</p> <p>a) Those MSEs have Quality Certification of ISI/ ISO / AgMark/ Quality Mark issued from competent authority in State or Central Govt. in respect of the items/ goods mentioned in the tender.</p> <p align="center">OR/AND</p> <p>b) Those who were registered with DGS&D/NSI / GOI Department/ State Govt. Department / GOI PSUs/ State Govt. PSUs in respect of the item/ goods mentioned in the tender.</p> <p>The firm will be required to submit the detailed information in respect of above through an affidavit as per the format enclosed as Annexure-D-I</p>
2	Earnest Money Deposit (EMD)	Exemption on the payment of Earnest Money Deposit (EMD) subjected to fulfillment of conditions as per eligibility	
3	Performance Security	90% concession on performance security as applicable to other Haryana based firm's subject to fulfillment of condition as per eligibility.	
4	Turnover	a) Micro Enterprises: Concession of 80% on turnover condition imposed as qualifying criteria. b) Small Enterprises: Concession of 70% on turnover condition imposed as qualifying criteria	
5	Past performance & Experience	Exempted in respect of Past Performance & Experience as part of requirements of the tender subject to fulfillment of conditions as per eligibility.	
6	Purchase Preference	50% of the total tendered quantity providing quoting price within band of L-I+15% by bringing down their price to L-I and subject to condition that it agrees to fulfillment of other terms & conditions of the tender and further subject to fulfillment to conditions as per eligibility.	

B. Concessions / benefits to Medium Enterprises:-

Sr. No.	Area as part of requirements	Concessions benefits allowed to MSEs	Eligibility
1	Past Performance & Experience	Exemption on requirements of Past Performance & Experience as part of requirements of the tender subject to fulfillment of conditions as per eligibility.	<p>Manufacturing Medium Enterprises of the state have filled Entrepreneur Memorandum for quoted items in Haryana, participated directly in tender and not through any intermediaries (their details/agents distributors), and will not subcontract to any other firm and to carry the entire manufacturing at their enterprises. This concession will be applicable only for one year to newly registered Medium Enterprises or Medium Enterprises of state who are not eligible in State Public Procurement due to eligibility criteria of Past performance & experience. The firm will be required to submit the detailed information in respect to above through an affidavit as per the format enclosed at Annexure-D-II</p>
2	Purchase Preference	10% of the total tendered quantity provided quoting price within band of L-I+15% by bringing down their price to L-I and subject to condition that it agrees to fulfillment of other terms & conditions of the tender and further subject to fulfillment of conditions as per eligibility.	

(Seeking benefits / concessions in past performance / Experience & Purchase Preference by Haryana based manufacturing Micro & Small Enterprises (MSEs) in the state Public Procurement)

(On non Judicial paper of Rs. 10/-)

I _____ S/o _____ aged _____ residing at _____
 _____ Proprietor / Partner / Director of M/s _____
 _____ do hereby solemnly affirm and declare that:-

1. My / our above noted enterprise M/s _____ (name & Address) _____ has been issued manufacturing Entrepreneurs Memorandum in Haryana by the District Industries Center _____ under acknowledgement No. _____ of dated _____ (Self certified copy of the same is attached as **Annexure-A** with this affidavit) and has been issued for manufacture of the following items in **category Micro / Small Enterprise** (please tick the either) as under:-
 - i) _____
 - ii) _____
 - iii) _____
2. That the quoted item(s) in the tender _____ is one (or more) of the item for which my/our above noted enterprise has been issued. Manufacturing Entrepreneurs Memorandum by the Industry Department Haryana as per details at para 1 above.
3. That my/our above mentioned manufacturing Micro/Small Enterprises fulfills either or both of the below mentioned eligibility criteria:-
 - i. That my/our above mentioned enterprise has been issued quality certification of ISI Mark/ ISO/ Ag.Mark/ any other quality mark _____ (please tick either of the option) by _____ (name of GOI/ State Govt. Agency/ Institution authorized by GOI/ State Govt.) on _____ and the same is valid from _____ to _____ in respect of item/ good (give name of item/ good) _____ mentioned in the tender (Self Certified Copy of the relevant certificate is attached as **Annexure A**' with this affidavit).
 - ii. That my/our above mentioned enterprises has been registered with DGS&D, GOI/NSIC/ Govt. of India Departments /State Govt. Department/ Govt. of India Public Sector Undertaking (PSUs) or State Government Public Sector Undertakings (PSUs) (Please tick one of the option as above) in respect of Name of item/ goods/work/services _____ (Name) as mentioned in the tender for the corresponding period of time of this tender. A self Certified Copy of the same attached as Annexure 'B' with this affidavit.
4. That in case the purchase order of the quoted item is issued to me/us, it will not be outsourced or subcontracted to any other firm and the entire manufacturing of the order item shall be done In-house by our Enterprises based in Haryana (address mentioned as at Sr. No.1) Further, the billing will be done from Haryana.

Dated:

DEPONENT

VERIFICATION:

Verified that the contents of para no. 1 to 4 of the above are true and correct to my knowledge as per the official record and nothing has been concealed therein.

Dated:

DEPONENT

(For seeking the benefits / concessions by Haryana based manufacturing Medium Enterprises in Past Performance / Experience & Purchase Preference in the state Public Procurement)

(On non Judicial paper of Rs. 10/-)

I _____ S/o _____ aged _____ residing at _____
_____ Proprietor / Partner / Director of M/s _____

do hereby solemnly affirm and declare that:-

1. M/s / our above noted enterprise M/s _____ (name & Complete Address) _____ has been issued manufacturing Entrepreneurs Memorandum in Haryana by the District Industries Center _____ under acknowledgement No. _____ of dated _____ (Self certified copy of the same is attached as **Annexure-A** with this affidavit) and has been issued for manufacture of the following items in **category Medium Enterprise** as under:-
 - i) _____
 - ii) _____
 - iii) _____
 - iv) _____
2. That my/our above mentioned manufacturing Medium Enterprises meet all the remaining terms & conditions of the tender except Past Performance / Past Experience.
3. That my first Purchase order under this benefit / concession was issued by State Government Department / State Government Agency (name of Deptt. / Agency) _____ vide P.O. No. _____ of dated _____ for the supply of _____ (name of the item/good/works/services) was successfully complied by above mentioned Enterprises. A self certified copy of the same is attached as **Annexure-B** with this affidavit.
4. That in case the Purchase Order of the quoted item is issued to me/us, it will not be outsourced or subcontracted to any other firm and the entire manufacturing of the order item shall be done in-house by our enterprise based in Haryana, (address mentioned as at Sr. No.1).
5. That we agree to the condition that this benefit / concession to the Medium Enterprise is valid for one year from the date of getting the first supply order under state Public Procurement.
6. That the billing will be done from Haryana.

Dated:

DEPONENT

VERIFICATION:

Verified that the contents of para no. 1 to 6 of the above are true and correct to my knowledge as per the official record and nothing has been concealed there in.

Dated:

DEPONENT

Following Details must be provided/accepted by the bidders in the Part-I offer, otherwise the tender is likely to be rejected.

Sr. No.	As per Tender Specification	To be accepted by the firm	Remarks
1.	Material specification- As per Annexure- 1 of Schedule C		
2.	Prices: Should be firm and F.O.R. DCRTTP, Yamuna Nagar.		
3.	HSN Code & GST		
4.	Delivery Period: Material Shall be supplied within 03 months from the 7 th day from the date of PO. As per Annexure-'1' to Schedule-'C'		
5.	Security Deposit: Security deposit @ 2% of total case value valid for successful supply of material.		
6.	PBG- PBG @ 10% of the total case value valid for successful completion of G/W period.		
7.	Damage for delay (LD): As per clause no. 8 of tender set.		
8.	Transit Insurance: Material to be dispatched duly insured at the cost of supplier/As per provision in PO. As per clause no. 13 of tender set.		
9.	Payment Terms: 100% payment after 21 working days of receipt of material along with PBG@ 10%.		
10.	Validity: 120 days from opening of price bid. As per clause no. 10 of Instructions To The Bidders.		
11.	Guarantee/Warranty: As per clause no. 14 & 15 of tender set.		
12.	Inspection: As per clause no. 9 of tender set.		
13.	Tender documents: Duly signed/ stamped by supplier to be submitted along with drawings. As per clause no. 8 of Instructions To The Bidders.		
14.	Test Certificate: To be submitted along with dispatch documents, As per clause no. 9 of tender set.		
15.	Interchangeability: As per clause no. 22 of tender set		
16.	Bank Charges: All bank charges to be borne by supplier.		
17.	Submission of recent P.O. copies for similar spares from Govt./ NTPC/ SEB deptts. As per clause no. 1 (iv) of Instructions To The Bidders.		
18.	Demurrages:- If any to be borne by Supplier. As per clause no. 17 of tender set.		
19.	Mode of Transport :- As per clause no. 12 of tender set.		
20.	Terms/conditions of Anexure-1, 2, 3 to Schedule C, Annexure- D .		

Your offer will be considered only after the acceptance of all the terms & condition mentioned above. Please accept strictly as per above details and submit the required documents for the opening of Part-II (Commercial bid), otherwise your tender is likely to be rejected.

for XEN/ Procurement-I,
Chief Engineer,
DCRTTP, HPGCL,
Yamuna Nagar

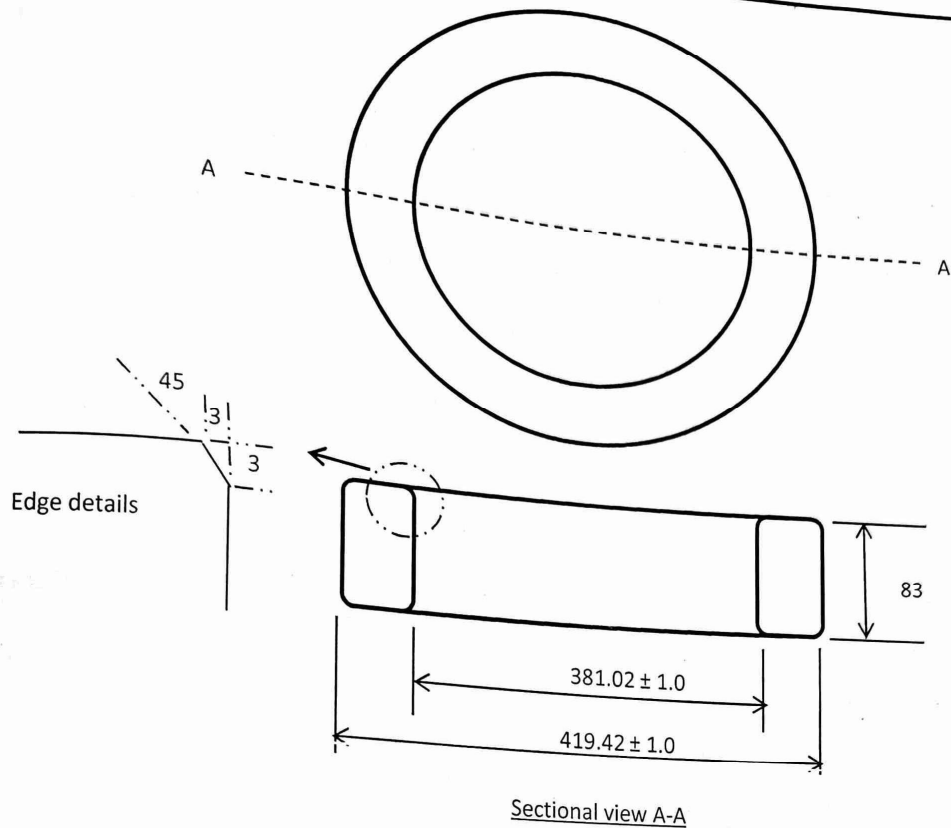

Sectional view A-A

Note:-

- Drawing is not to scale
- All Dimensions are in mm
- Hardness should be 55 RC minimum
- Material should be mirror finished of Grade 3 Triangle
- Periphery should be case hardened upto 5mm radially

Seal Wear Ring

(Hardness : 55 RC minimum)

MOC : EN-31

Drawing no :- BL-250155

